

# REFRIGERATING CABINETS

## CHS



The BRATŘI HORÁKOVÉ s.r.o. Company, a Czech producer of cooling equipment is introducing an innovated model range of professional refrigerating cabinets. The cabinets are designed for **storing food, meals, bakery and other products**. Our offer includes cabinets allowing you to use **GN containers, crates, baking sheets, KEG barrels, waste containers**, etc.

The offer is based on CHS models with the internal height of 1080 and 1540 mm. The internal depth of the cabinets is 690 or 910 mm respectively. The width of the internal space is 600 or 1400 mm. The variability of the system makes it possible to supply one, two and three-

winged door cabinets. The internal width of the single door cabinet is 600 mm, 605 mm for the two-winged version and 606 mm for the three-winged version.

Combinations of the above mentioned dimensions have created the standard offer of volumes: 640, 970, 1380, 1820 l and 2100 l (3 wings version).

The thickness of insulation is 50 mm /environment-friendly CFC PU foam with reduced flammability/.

The CHS cabinets conveniently complement the complete range of cooling equipment for gastronomy and retail consisting of model ranges of:

- **KLASIK** and **MINI** coldrooms (3 to 48 m<sup>3</sup>)
- **KOMBI** refrigerating cabinets (780 to 3460 l): this variable system offers 1 to 6 separate cooling areas in one formation,
- **VK** and **VP** display cabinets,
- **ZCM**, **ZC** and **ZM** blast chillers and freezers.

### *Saving space, powers and investment...*

The standard versions of cabinets have the cooling unit on the ceiling in a block arrangement. Unlike other layouts the evaporator **does not reduce the effective space** of the box. In both the alternatives each area is controlled separately. In standard versions the cabinets are equipped with units having a sufficient performance for storing products within the range of area temperatures of 0°C to 10°C. Some models are also designed for the range of temperatures of +5°/+10°C. On request cabinets can be delivered that are suitable for connection to a split or multi-compressor systems.



**Variable arrangement – internal accessories...**

Customers can choose various ways of storing products and internal accessories as e.g.:

- Adjustable tray holders for storing GN or baking trays
- A shelf system with selectable spacing of shelves (stainless-steel or lacquered sheets)
- Storing in crates, meat suspension systems (stainless-steel finish), etc.

**Surface finish** is selectable – stainless steel /AISI 304–fine grinding/ or galvanized, white lacquered steel sheet. Take interruption of heat bridges for granted.

**The doors** are equipped with replaceable magnetic gaskets. On request they can be equipped with a lock. For selected sizes we can offer glazed doors. From cabinets with glazed doors there is just a step to display cabinets...please, obtain information about our range of **VK and VP** display cabinets for butchers, sausage-makers or confectionery.

As optional accessories we also offer:

- A digital temperature controller with registration of alarm conditions output to data collection
- Illumination,
- **Rounded corners** of inner spaces.

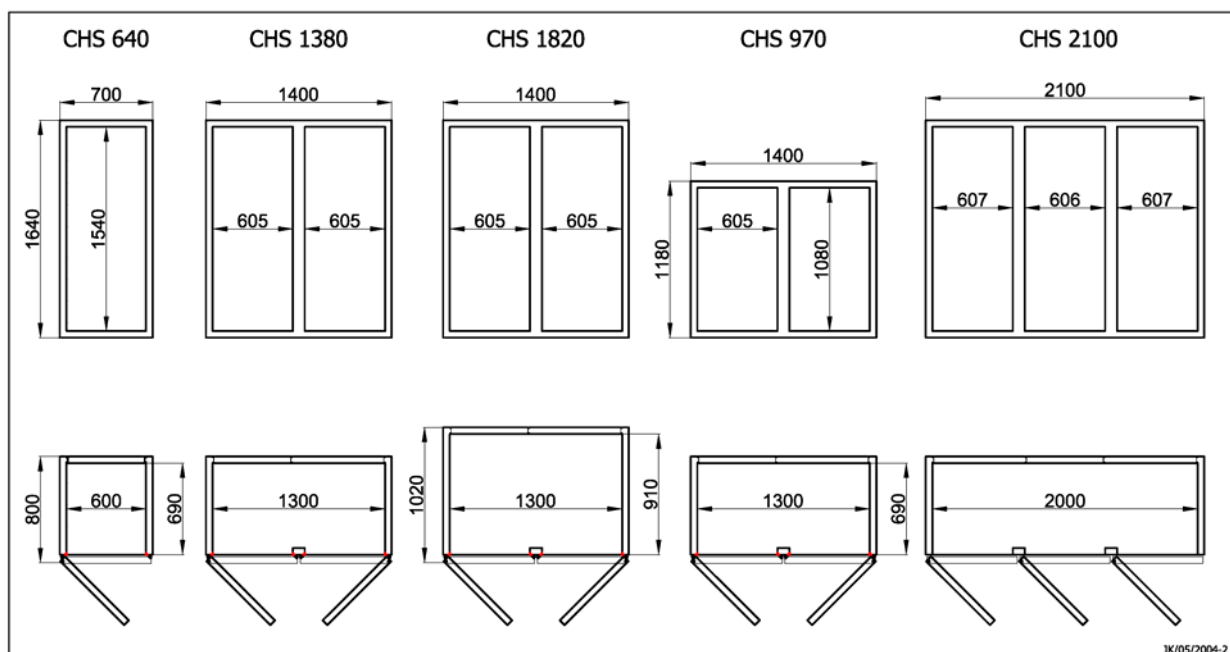

Drw. 1 – dimensioned sketch



Drw. 2 – ceiling with block cooling unit



Drw. 3 –Example of internal accessories

**Company address:**

✉ Mělnická 150, 277 06 Lužec nad Vltavou

☎ +420 315 619 111

☎ +420 315 619 999

✉: [horak@horak-bros.com](mailto:horak@horak-bros.com)

<http://www.horak-bros.com>

**Export department:**

☎ +420 315 619 104

☎ +420 315 619 110

☎ +420 315 619 999

✉: [export@horak-bros.com](mailto:export@horak-bros.com)

Manufacturer reserves the right to modify technical features without notice.